

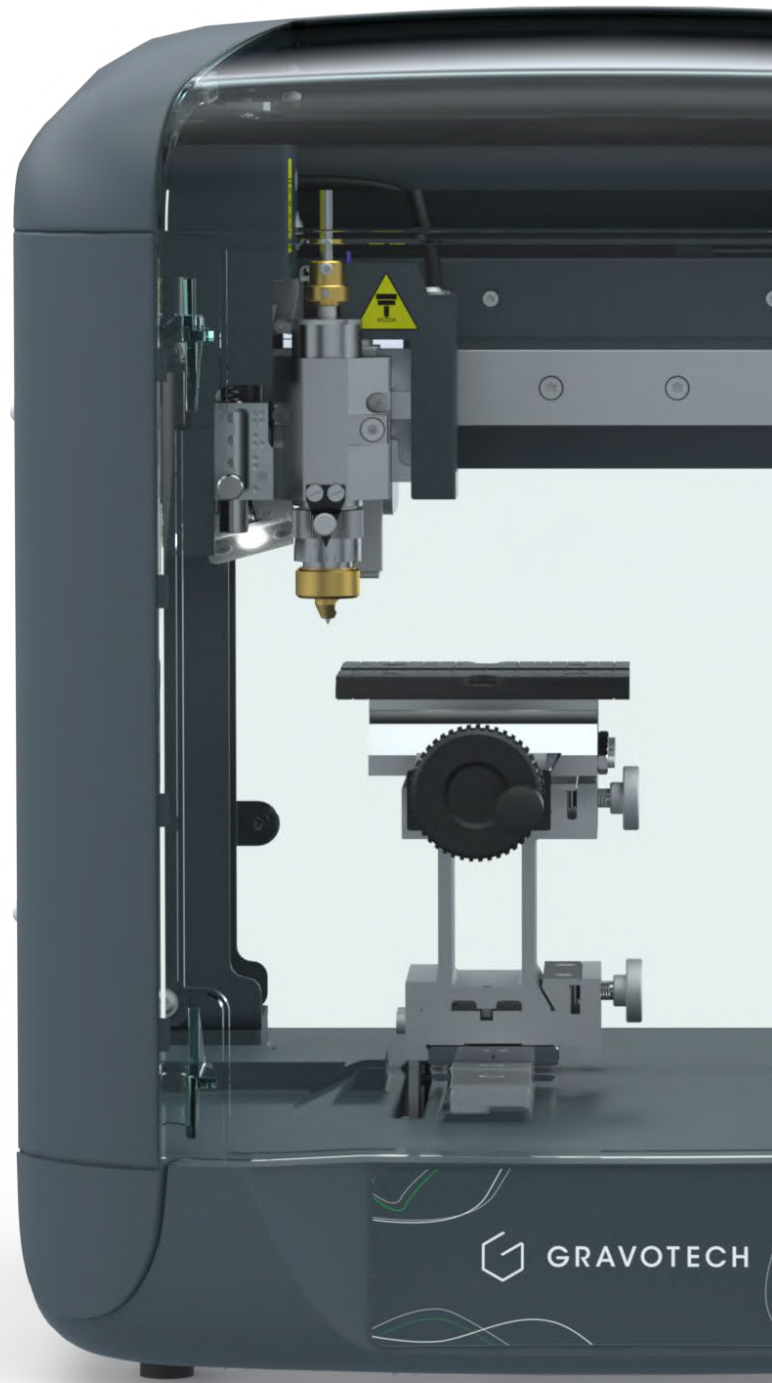

ENGRAVING STATION

M20 X



GRAVOTECH

by  **BRADY**



As the best-selling rotary engraver in the world, the M20 X can adapt to any purpose and fit any job. Small and lightweight, you can find a place for the M20 X in every shop, workshop and even take it on a promotion tour.

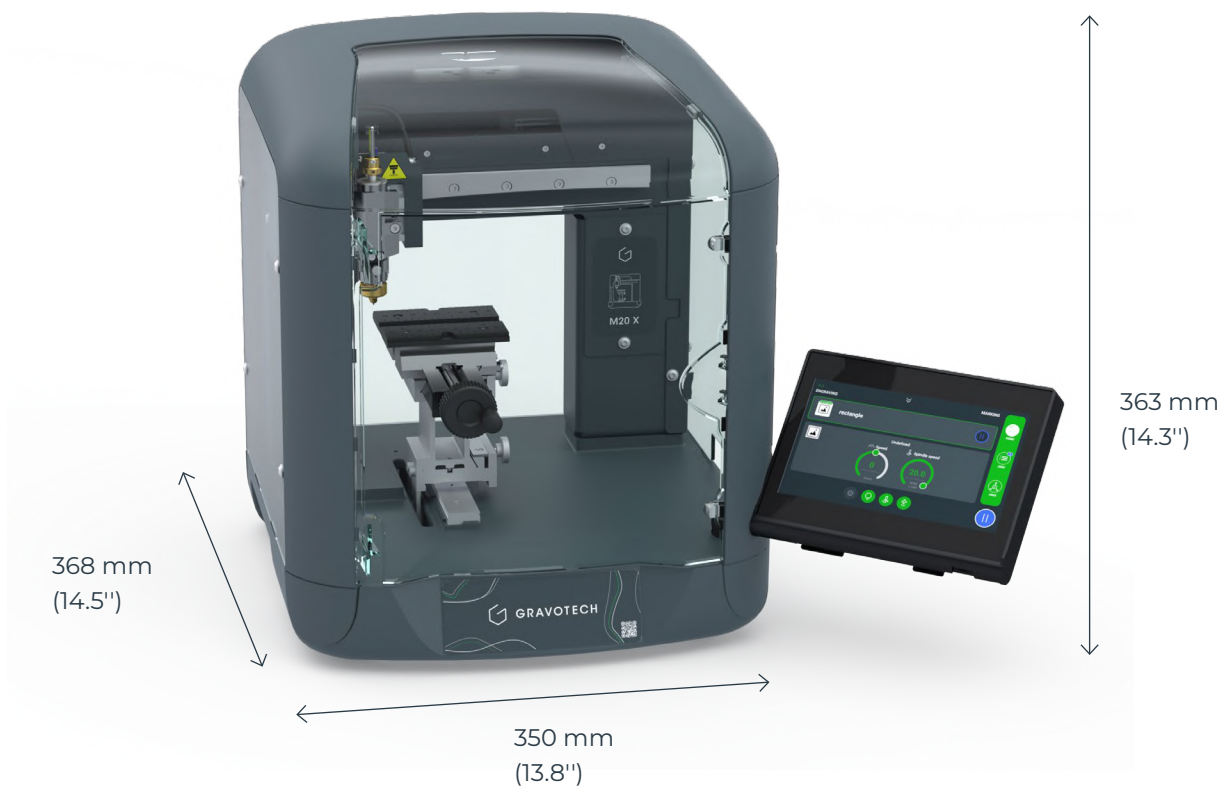

VERSATILE

The M20 X evolves around you. Whatever your business is and the products you want to engrave, different add-ons are available from the rotary device, different jigs and tools. Thanks to decades of experience in engraving, Gravotech has the widest range of jigs and accessories for custom engraving, perfect to personalize gifts (perfumes, pens, keyrings), medals or door plates.

EASY-TO-USE

The touch screen, the last innovation, guides you through the engraving process step by step, making the M20 X the best user-friendly machine. You can manage the engraving queue on the screen to start engraving any projects you want. Many accessories and features are available to engrave easily: jigs, cutting table, Gravogrip table, G-Eye, Point & Shoot and automatic Z axis. You can also send your jobs effortlessly to the machine thanks to the Wi-Fi connection.

RELIABLE

As the original inventor of the technology, Gravotech brings over 80 years of industry expertise, offering unmatched knowledge and reliability. The M20 X is the ideal sturdy and compact engraving machine for professional, high-quality engravings and cuts. This durable machine is also low maintenance, involving low aftersales costs! Our expert technicians can also quickly diagnose any issue at a glance, ensuring reactive and efficient maintenance. Its robust X, Y, and Z axes are equipped with ball screws, ensuring precise and reliable performance over time. Additionally, the new generation of electronic boards brings enhanced functionalities such as built-in Wi-Fi.

SEE OUR VIDEO



KEY FEATURES



Smart touch screen

Manage easily and quickly every step of the engraving process through the screen:

- Check out the preview before starting to engrave,
- Adjust engraving settings with ease,
- Manage the engraving queue as you wish.

The M20 X adapts to its environment, the screen can be placed on top or on the right side of the machine according to your use.

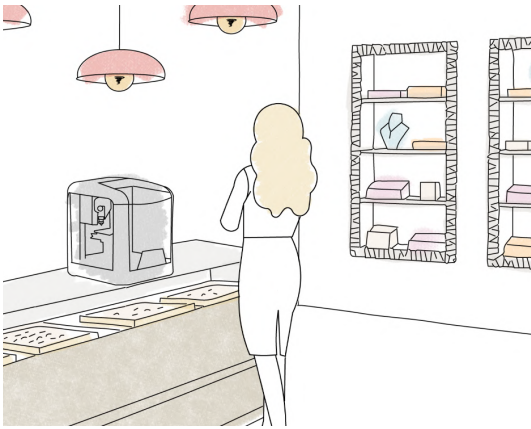

M20 X, perfect for your shops and events

The M20 X is the perfect engraving machine for creating in-store events.

Thanks to its compact size and lightweight design, it seamlessly integrates into any retail environment, making it exceptionally easy to position wherever you want. The transparent cube highlights your product being engraved while ensuring total safety.

Its sleek design in a retail environment attracts the curiosity of your customers and creates buzz. This is the ideal solution to adding value to your products.

ACCESSORIES



G-Eye

The camera G-Eye allows fast preview and quick positioning of the engraving on the product. Designing the engraving on complex and irregular shapes is now easy with the camera G-Eye.



Jewel Pack

Thanks to the rotary device and various jigs for jewels, you can personalize both the inside and outside of rings. With specialized cutters and diamonds, this machine is the perfect complement to your creations!

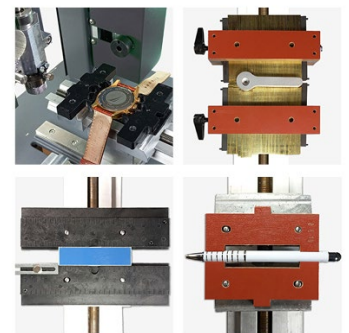

Large jigs range

More than 25 jigs are compatible with the M20 X, whatever the signage or personalization application: electrical strips, jewelry, swiss army knives, tableware, funerary plates, cosmetics or perfume engraving...

LEARN MORE ABOUT THE M20 X



APPLICATIONS



Industrial signage



Personalizing and engraving jewelry



Funeral plaques and headstones engraving



Glass engraving



Express Engraver



Small signage

MATERIAL CHARACTERISTICS

Technology		ROTARY	DIAMOND ENGRAVING
Materials	Glass, crystal	●	●
	Metal	◄○●	●
	Plastics	◄○	
	Engraving materials	◄○●	●
	Stone, granit, marble	○●	
	Wood	◄○	
	Leather	◄○	
	Ceramic	●	●

◄ = Cutting ○ = Engraving / Deep marking ● = Marking / Etching

EXPLORE SPECIFIC APPLICATIONS



SOFTWARE

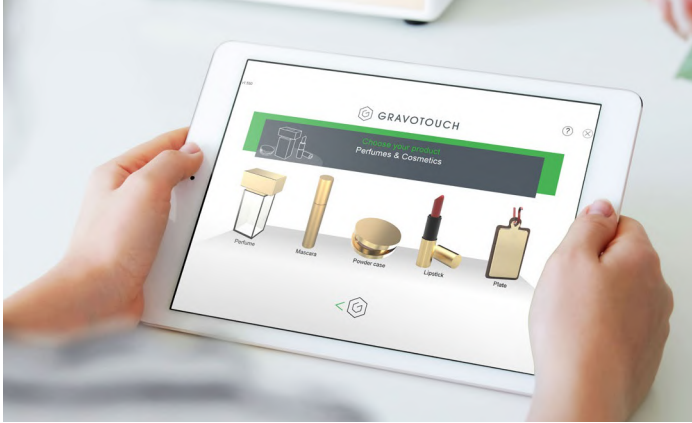

Product catalog software

Do you have a limited range of products to engrave? Our catalog software is the right choice for you! Contact us for a customized version that integrates your specific range of products.



Gravostyle™

One-of-a-kind piloting software for Gravotech laser and rotary engraving machines. Create your engraving, send it to your Gravostyle machine and watch as your engraving appear in front of your eyes! Many features are available: Photostyle and 2D Filling (by Color).

SERVICE & SUPPORT



Training

Standard or customized training sessions, at your place or online.



Technical support

Gravotech experts dedicated to support and guide you.



Maintenance

Gravotech has established a dedicated program for each machine type, including cleaning, adjustments, safety checks and more.

TECHNICAL DATA

M20 X

Max. marking area (L x W)	100 x 100 mm (option: 120 x 100 mm) 3.94 x 3.94" (option: 4.72 x 3.94")
Machine dimensions (L x W x H)	Right-side touchscreen: 375 x 550 x 408 mm (14.76 x 21.65 x 16.06") Top touchscreen: 375 x 350 x 552 mm (14.76 x 13.77 x 21.73")
Machine weight (kg)	12.9 kg (28.43 lbs)
Max. object size (L x W x H) (weight)	190 x 110 x 100 mm (7,48 x 4.33 x 3.94") - (10 kg - 22,04 lbs)
Connection to computer	USB / Ethernet / WiFi
Software	Gravostyle / Gravotouch
Maximum speed	40 mm/s (1,58 in/s)
Point & shoot	Yes
Automatic Z axis	Yes
Z stroke (Z travel)	30 mm (1.18")
Spindle type	Top load spindle Hollow shaft motor
Rotation speed	up to 19200 rpm
Tool diameter	4,36 mm (0,17")
Noise level	up to 62 dB
Operating temperature	min. +5°C (+ 41°F) - max. +40°C (+104 °F)



GRAVOTECH

by  BRADY

info.cn@gravotech.com

+86 21 24 08 68 88

www.en.gravotech.cn

**GRAVOTECH (SHANGHAI)
ENGRAVING EQUIPMENT
CO.,LTD.**

Building F, No. 1835 Duhui Road,
Minhang District
201108, Shanghai, China

Distributed by:

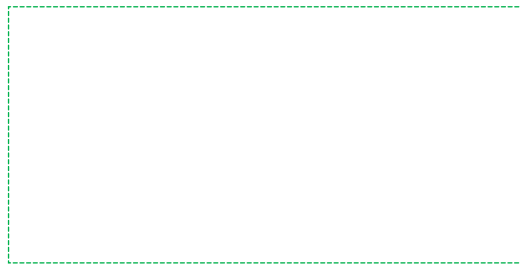

Follow us:



[gravotech.off](https://www.instagram.com/gravotech.off)



[Gravotech Group](https://www.youtube.com/Gravotech Group)



[Gravotech](https://www.linkedin.com/Gravotech)



[Gravotech - Gravograph](https://www.facebook.com/Gravotech - Gravograph)